

CRAZYFLY

HEXA
B I N D I N G

USER MANUAL

PACKAGE CONTENTS

①

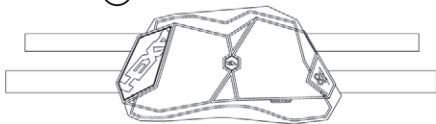

②

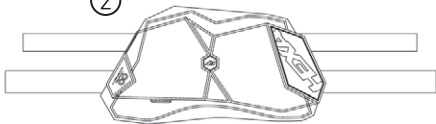

③

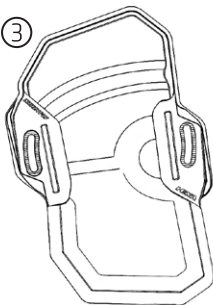

④

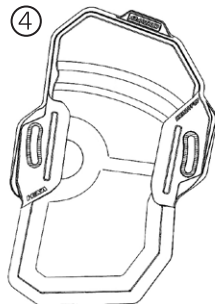

⑤

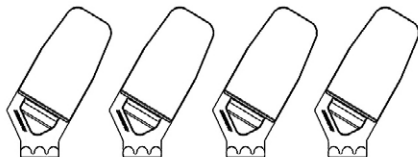

⑥

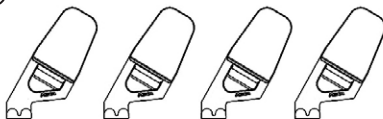

⑦



⑧



- ① 1 x Hexa footstrap Left - L
- ② 1 x Hexa footstrap Right - R
- ③ 1 x Hexa footpad Left - L
- ④ 1 x Hexa footpad Right - R
- ⑤ 4 x Quattro Stix Long
- ⑥ 4 x Quattro Stix Short
- ⑦ 4 x Screw M6 x 20
- ⑧ 4 x Hexa washer

1 x Hexa bag

1 x Manual

HOW TO MOUNT

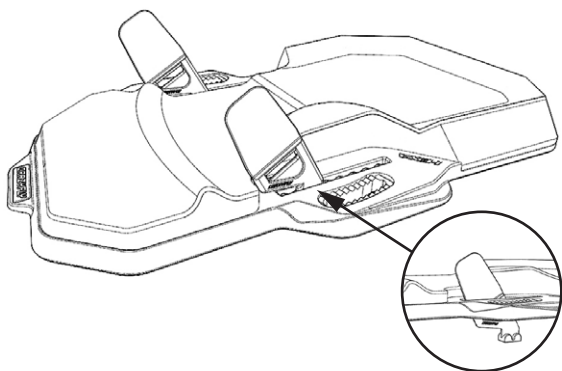

- 1.** Take 1 pc Quattro Stix Short and 1 pc Hexa footpad Right. Place the Quattro Stix Short in the front position of the Hexa footpad frame on the left and on the right side.

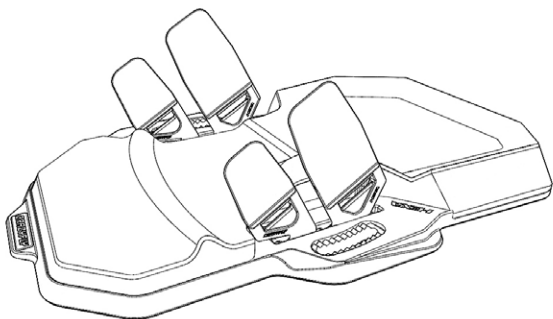

- 2.** Take 1 pc Quattro Stix Long and continue on the Hexa footpad Right. Place the Quattro Stix Long in the back position of the Hexa footpad frame on the left and on the right side.

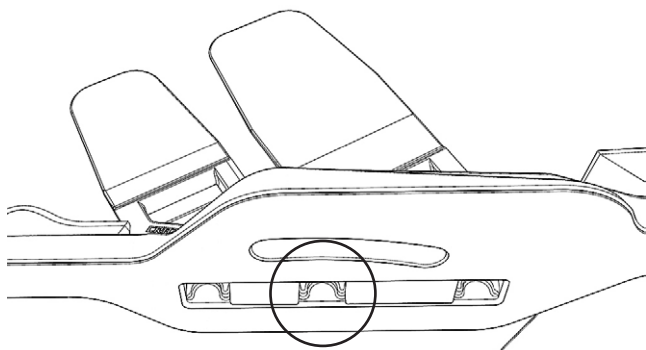

- 3.** Adjust all Quattro Stix to the desired position. Make sure there is one empty position between Quattro Stix Short and Quattro Stix Long.

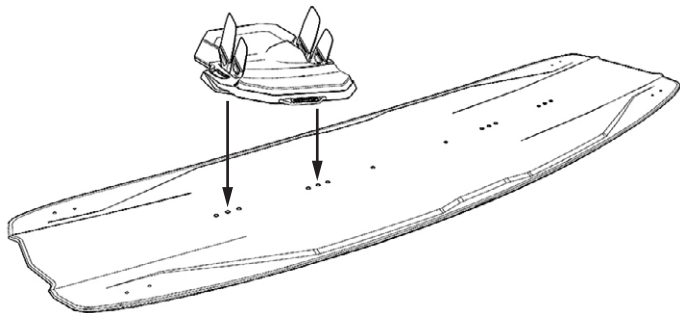

- 4.** Place the Hexa footpad Right on the board and select desired insert position. This determines your stance width.

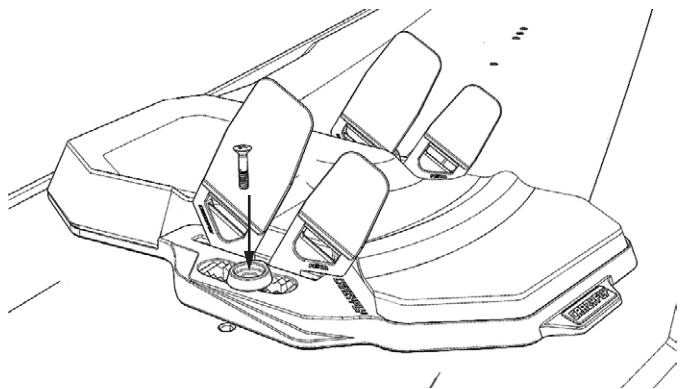
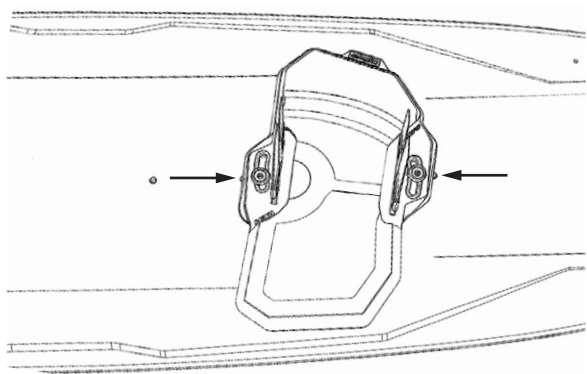

- 5.** Put 2 pcs Hexa washers in place, one to the left and the other one to the right side of the Hexa footpad. Make sure the holes in the washer are aligned with the inserts on the board. Tighten 2 pcs screws slightly - left and right side of the Hexa footpad.

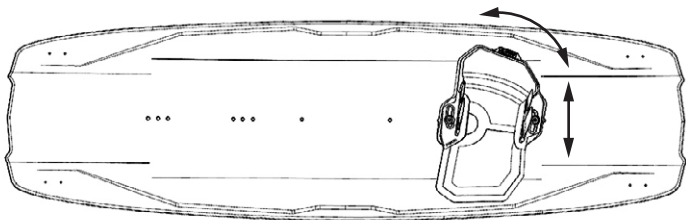

6. Adjust the Hexa footpad angle to the desired position.

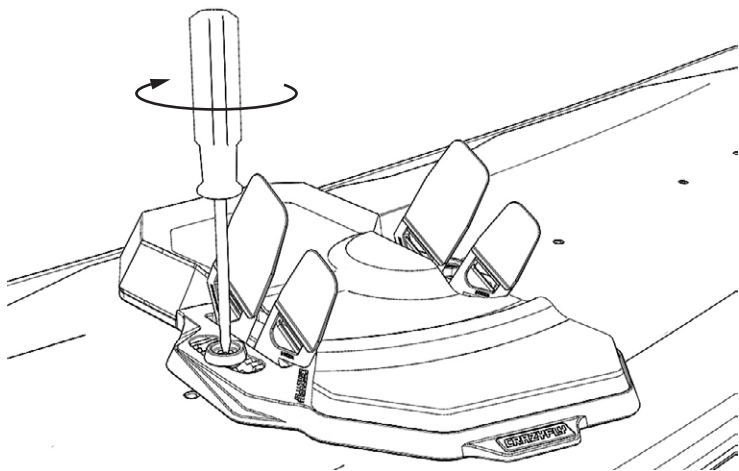

7. Fully tighten the screws. Please check the footpad screws after the first few rides, as they may come loose. If loose, make sure to fully tighten the screws.

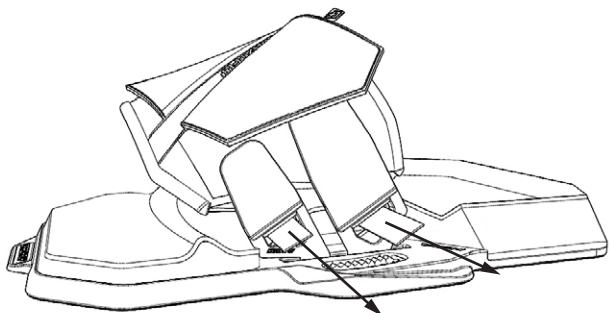

- 8.** Take the Hexa footstrap Right and open the velcro. Thread the velcro through the Quattro Stix. It is best to start on the Quattro Stix Long in the left side of the Hexa footpad right (inside of the foot). Then continue with threading the velcro through the Quattro Stix Short on the same side.

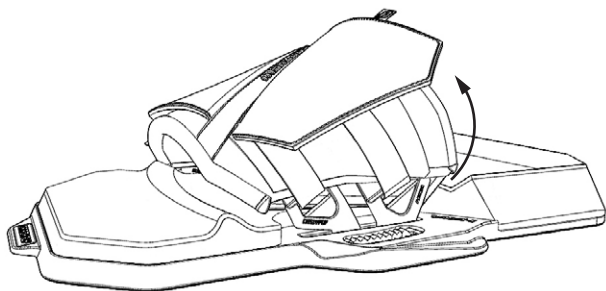

- 9.** Slide the Quattro Stix inside the footstrap. Slightly tighten and close the threaded velcros. Leave the velcros a bit loose and close the top velcro. Leaving the velcro loose will make threading the velcro on the other side of the footpad easier.

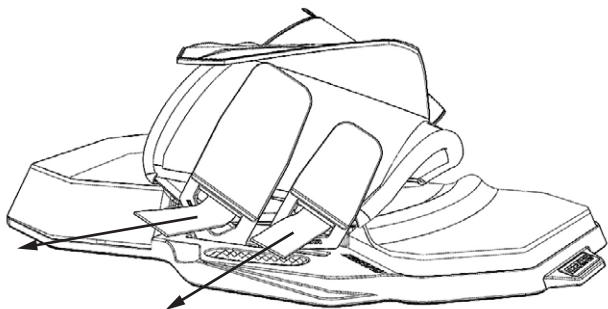

- 10.** Thread the Velcro through the Quattro Stix on the right side (outside of the foot) on the Hexa footpad Right.

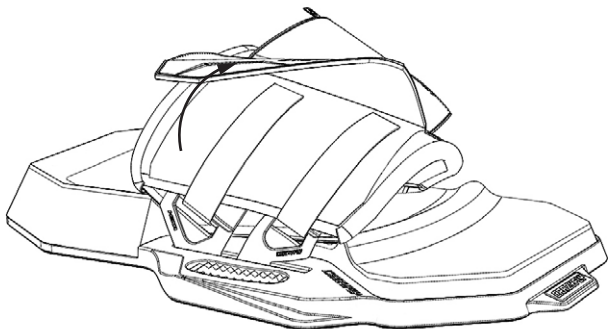

- 11.** Slide the Quattro Stix inside the footstrap. Tighten and close the velcro.

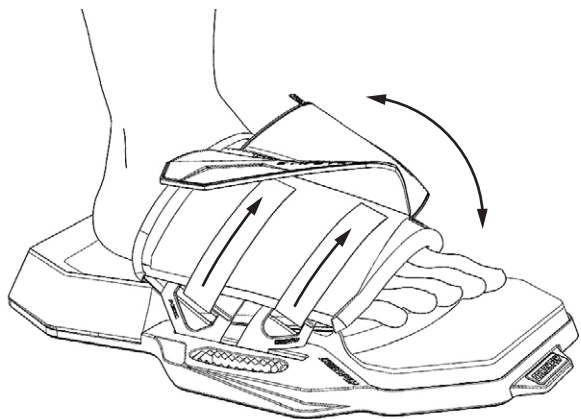

12. Step inside the Hexa Binding.

13. Adjust the Hexa footstrap with the velcros for the best fit.

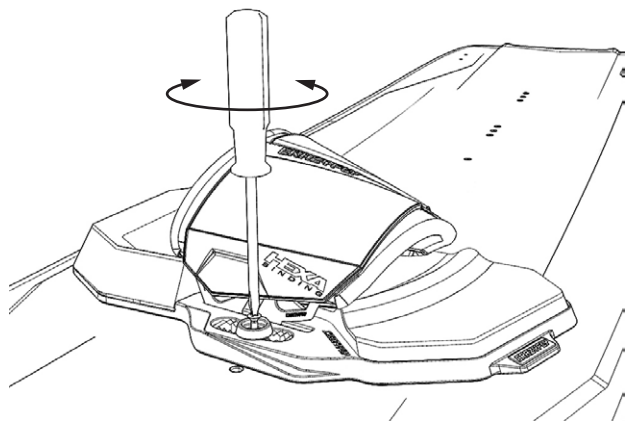

14. If further adjustments for the angle of the binding is needed, loosen the screws a little until the Hexa Binding is able to spin. Adjust the angle again to the desired position and fully tighten the screws.

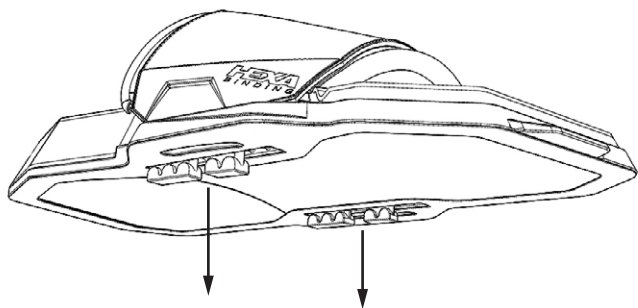
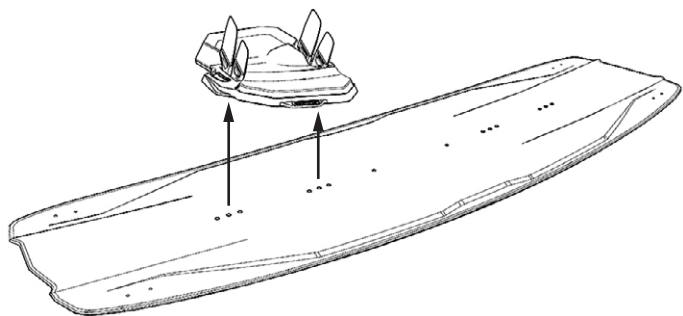

15. If further adjustments for the footstrap position and footpad position are needed, undo the screws completely. Lift up the Hexa Binding, push the Quattro Stix down so they pop out of the Fusion Frame. Adjust the Quattro Stix to the desired position and pop them back in the Fusion Frame. Mount the Hexa Binding back on the board to the desired position and fully tighten your screws.

16. Enjoy the ride!

CRAZYFLYKITES.COM



**KB BY BUYING THESE PRODUCTS
CH YOU SUPPORT CHILDREN.**

kiteboardingforchildren.com



**REGISTER
YOUR GEAR**

crazyflykites.com/register